

O-I Sales and Distribution Italy s.r.l.

Via 1° Maggio, 18
21040 Origgio(VA), Italy
Tel. +39 0243453.1

CONTAINER & MOULD ENGINEERING

EUROPE

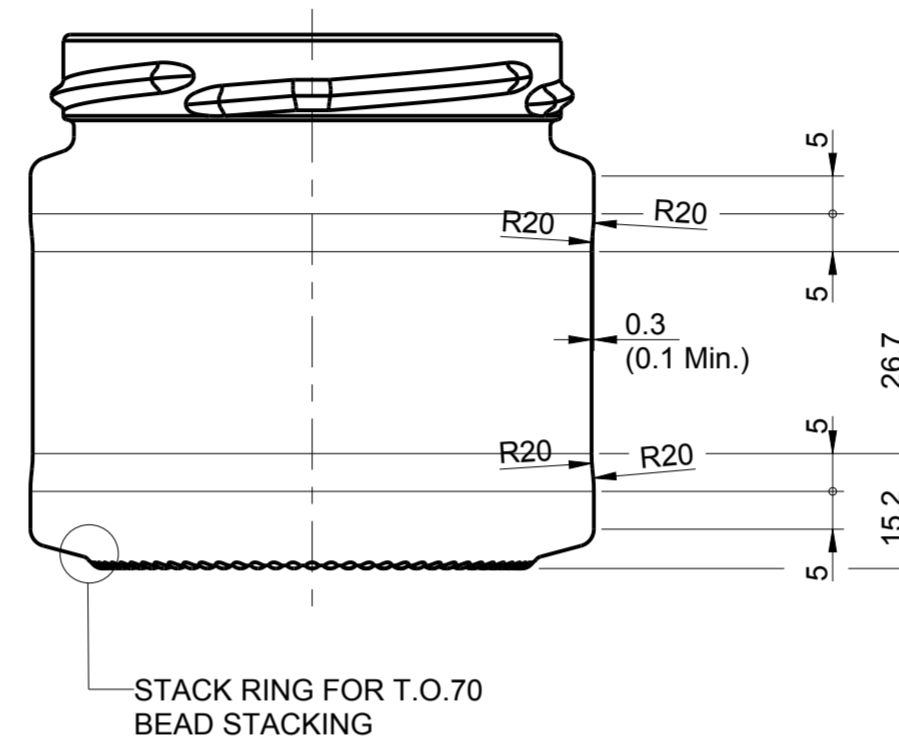
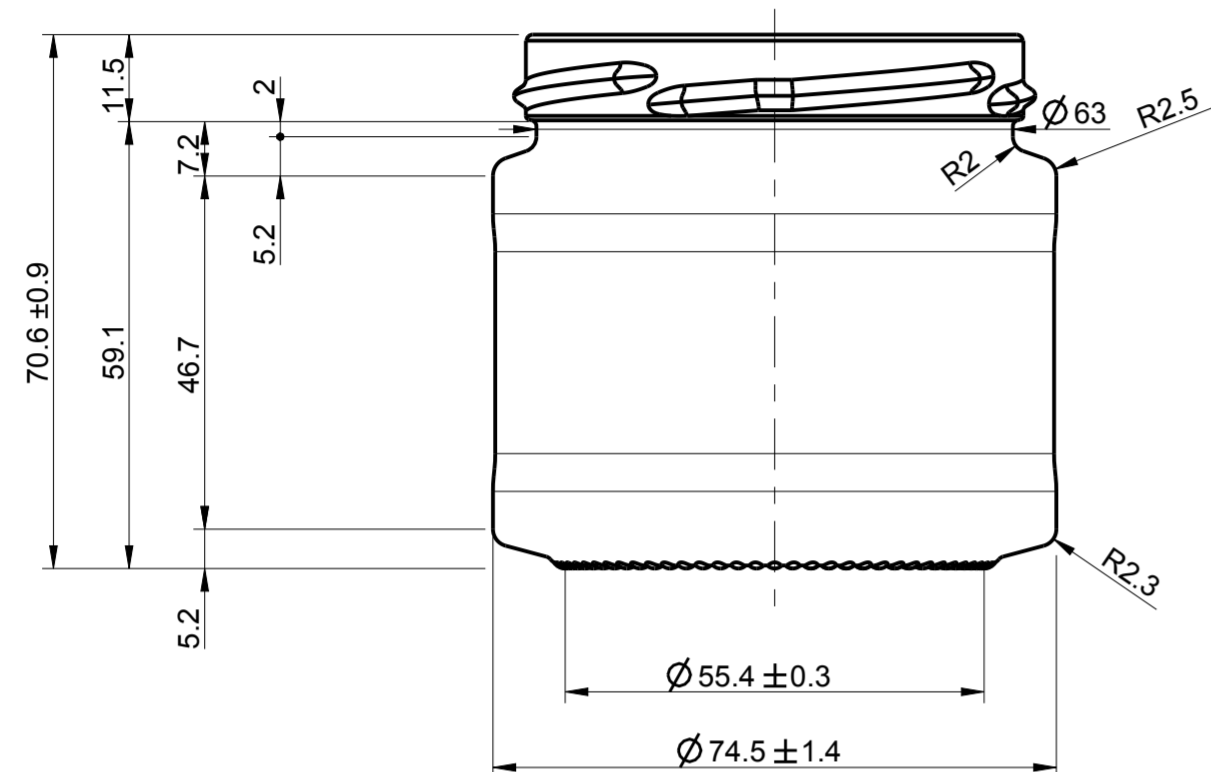

NOTES:
THIS DRAWING IS THE PROPERTY OF O-I AND
MUST NOT BE REPRODUCED OR DISCLOSED
WITHOUT O-I WRITTEN AUTHORIZATION.

DIMENSIONS EXPRESSED IN mm
ONLY TOLERANCED DIMENSIONS ARE GUARANTEED.

MANUFACTURING MARKINGS SHOWN ARE FOR ILLUSTRATIVE
PURPOSES ONLY. ACTUAL MARKINGS ON CONTAINER
MAY DIFFER, DEPENDANT ON LOCAL LEGISLATION.

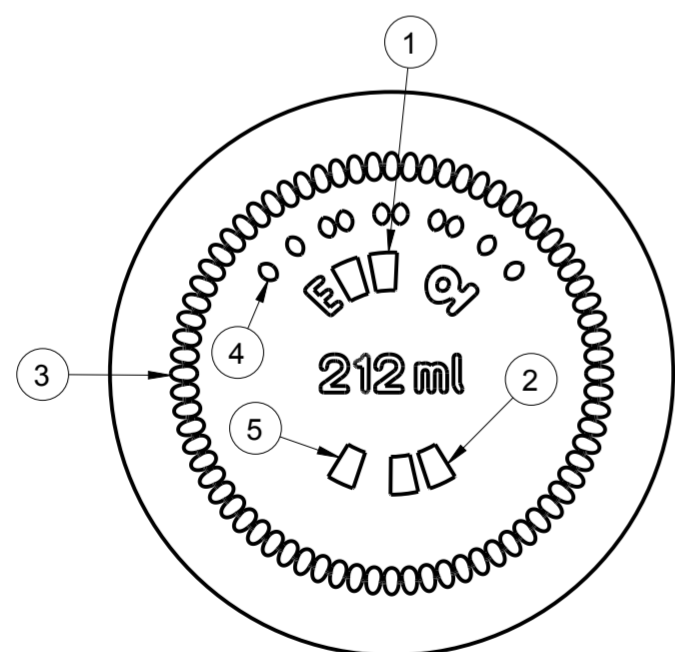

CATEGORY FOOD	TILT ANGLE 40.75°
MAX. VERTICALITY TOLERANCE 1.27 mm	MEASURING CONTAINER NO
FINISH SAP NUMBER 4966	FINISH REF. CETIE GME 20-06 1995
MINIMUM THROUGH BORE mm	MAX FILLING TUBE Ø mm
CONTAINER OVERFLOW CAPACITY (BRIMFUL)	
212ml ± 6ml	
CONTAINER RATED CAPACITY (FILLPOINT)	
CONTAINER WEIGHT	
170g APPROX.	
FINISH DESIGNATION EU_70_GME 20-06_H115_4966	MAX GAS VOLUME
PROCESS	RETURNABLE NO
	DESIGN REF.

STANDARD
21.2 CL MINIMAL TO 70 SE

DESIGNER	MP	DATE	06/04/18
CHECKED		DATE	
DRAWING NUMBER	MOULD/SAP NUMBER		
180276	180276		

1 = TRADEMARK
2 = CAVITY No.
3 = STIPPLING
THE SHAPE OF STIPPLES IS ONLY AN
INDICATION AND THE CONSTRUCTION IS AT
THE PRODUCTION PLANT DISCRETION.
4 = CAVITY CODE
5 = A GLASS IDENTIFICATION

SCALE 1:1

No	DATE	REVISIONS	DESIGN/CHECK
	20/06/18	INCREASED BODY DIAMETER AND WEIGHT	GP
	30/05/18	ADDED SAP/Number	GP